

modello: modell:	FRIDA
codice: code:	5132
design:	ABS studio
anno - year:	---
tipologia: tipology:	lampada da parete o plafone wall or ceiling lamp
materiali: materials:	vetro soffiato satinato bianco white blown matt glass
luce: light:	diffusa diffuse
lampadine - bulbs:	75W E27 21W E27 fluo EL
grado IP - IP grade:	40
peso netto - net weight:	.57 - 1 Kg .33 - 1,80 Kg
finiture: finishes:	.33 acciaio satinato .57 vetro bianco .33 matt-steel .57 white glass
marcatura: marking:	CE
simboli costruttivi: symbols:	F

Dimensioni - Dimensions

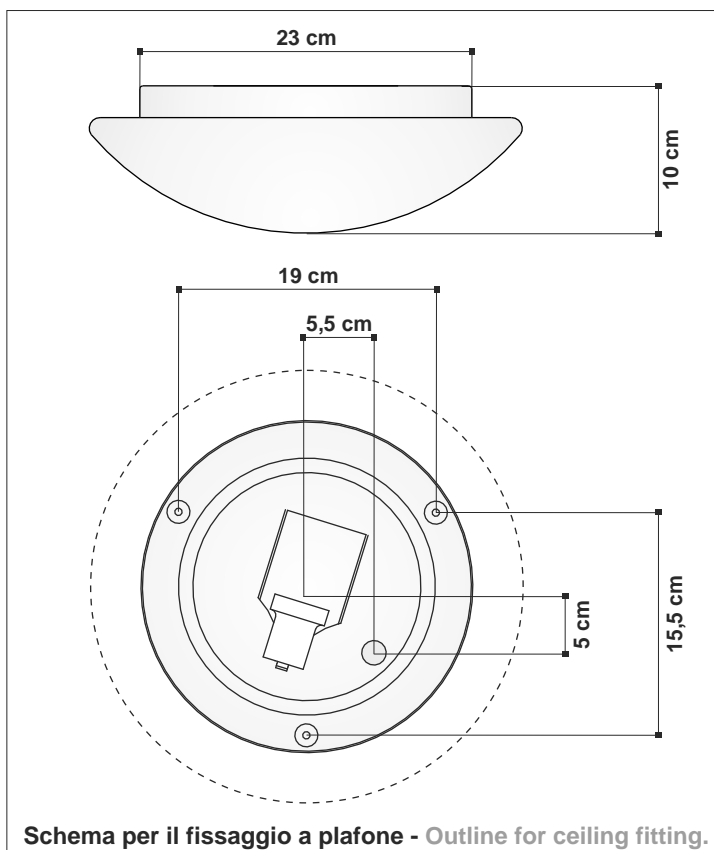
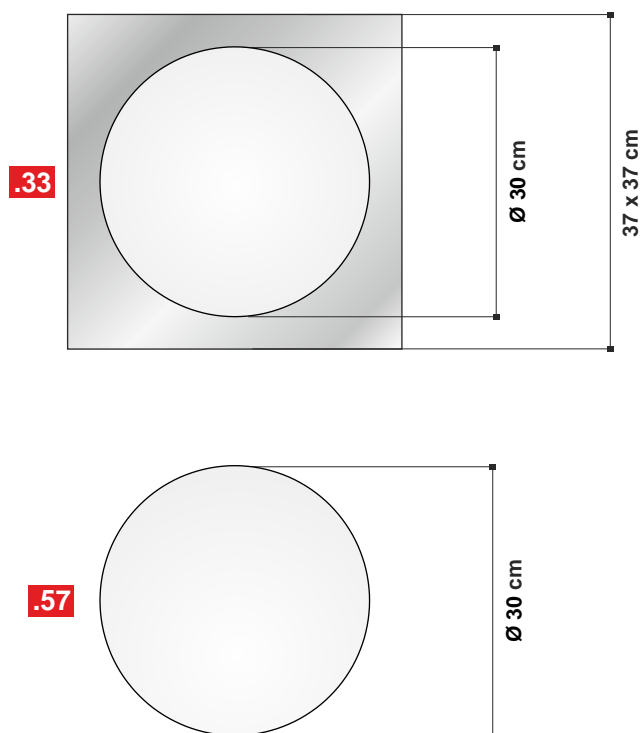

EGOLUCE s.r.l., via I. Newton 12 - 20016 Pero - Milano
 telefono +39 02 339586.1 - fax. +39 02 3535112
 e-mail: info@egoluce.com - http://www.egoluce.com